

## Double channel high-side solid-state relay

### Features

Type	$R_{DS(on)}$	$I_{OUT}$	$V_{CC}$
VND600	35 m $\Omega$	25 A <sup>(1)</sup>	36 V

1. Per channel with all the output pins connected to the PCB.

- CMOS-compatible input
- Proportional load current sense
- Shorted load protection
- Under-voltage and over-voltage shutdown
- Over-voltage clamp
- Thermal shutdown
- Current limitation
- Protection against loss of ground and loss of  $V_{CC}$
- Very low standby power dissipation
- Reverse battery protected (see [Application schematic](#))

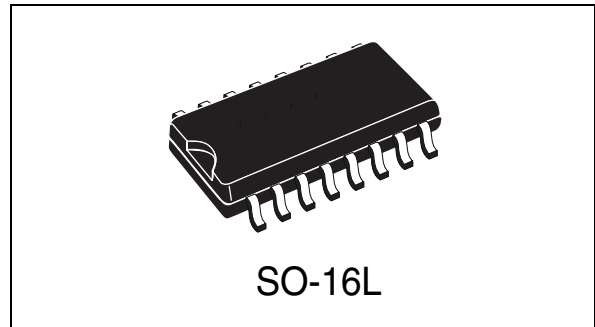

### Description

The VND600 is a double chip device designed in STMicroelectronics VIPower M0-3 technology. The VND600 is intended for driving any type of load with one side connected to ground. The active  $V_{CC}$  pin voltage clamp protects the device against low energy spikes (see ISO7637 transient compatibility table). Active current limitation combined with thermal shutdown and automatic restart protects the device against over-load.

The device integrates an analog current sense output which delivers a current proportional to the load current. The device automatically turns off in the case where the ground pin becomes disconnected.

**Table 1. Device summary**

Package	Order codes	
	Tube	Tape and reel
SO-16L	VND600	VND60013TR

# Contents

<b>1</b>	<b>Block diagram and pin description</b> .....	<b>5</b>
<b>2</b>	<b>Electrical specifications</b> .....	<b>6</b>
2.1	Absolute maximum ratings .....	6
2.2	Thermal data .....	7
2.3	Electrical characteristics .....	8
2.4	Electrical characteristics curves .....	14
<b>3</b>	<b>Application information</b> .....	<b>16</b>
3.1	GND protection network against reverse battery .....	16
3.1.1	Solution 1: resistor in the ground line (RGND only) .....	16
3.1.2	Solution 2: diode (DGND) in the ground line .....	17
3.2	Load dump protection .....	17
3.3	MCU I/Os protection .....	17
3.4	Maximum demagnetization energy (VCC = 13.5V) .....	18
<b>4</b>	<b>Package and PCB thermal data</b> .....	<b>19</b>
4.1	SO-16L thermal data .....	19
<b>5</b>	<b>Package and packing information</b> .....	<b>22</b>
5.1	ECOPACK® packages .....	22
5.2	SO-16L packing information .....	24
<b>6</b>	<b>Revision history</b> .....	<b>25</b>

## List of tables

Table 1.	Device summary . . . . .	1
Table 2.	Suggested connections for unused and not connected pins . . . . .	5
Table 3.	Absolute maximum ratings . . . . .	6
Table 4.	Thermal data (per island) . . . . .	7
Table 5.	Power . . . . .	8
Table 6.	Switching ( $V_{CC}=13V$ ) . . . . .	8
Table 7.	$V_{CC}$ output diode. . . . .	8
Table 8.	Logic inputs. . . . .	9
Table 9.	Current sense ( $9V \leq V_{CC} \leq 16V$ ) . . . . .	9
Table 10.	Protections . . . . .	10
Table 11.	Truth table. . . . .	10
Table 12.	Electrical transient requirements . . . . .	11
Table 13.	Thermal parameters . . . . .	21
Table 14.	SO-16L mechanical data . . . . .	23
Table 15.	Document revision history . . . . .	25

## List of figures

Figure 1.	Block diagram . . . . .	5
Figure 2.	Configuration diagram (top view) . . . . .	5
Figure 3.	Current and voltage conventions . . . . .	6
Figure 4.	Switching characteristics . . . . .	11
Figure 5.	$I_{OUT}/I_{SENSE}$ versus $I_{OUT}$ . . . . .	12
Figure 6.	Waveforms . . . . .	13
Figure 7.	Off-state output current . . . . .	14
Figure 8.	High-level input current . . . . .	14
Figure 9.	Input clamp voltage . . . . .	14
Figure 10.	Turn-on voltage slope . . . . .	14
Figure 11.	Over-voltage shutdown . . . . .	14
Figure 12.	Turn-off voltage slope . . . . .	14
Figure 13.	ILIM vs Tcase . . . . .	15
Figure 14.	On-state resistance vs VCC . . . . .	15
Figure 15.	Input high-level . . . . .	15
Figure 16.	Input hysteresis voltage . . . . .	15
Figure 17.	On-state resistance vs Tcase . . . . .	15
Figure 18.	Input low-level . . . . .	15
Figure 19.	Application schematic . . . . .	16
Figure 20.	Maximum turn-off current versus inductance . . . . .	18
Figure 21.	SO-16L PC board . . . . .	19
Figure 22.	Rthj-amb Vs PCB copper area in open box free air condition . . . . .	19
Figure 23.	Thermal impedance junction ambient single pulse . . . . .	20
Figure 24.	Thermal fitting model of a quad channel HSD in SO-16L . . . . .	20
Figure 25.	SO-16L package dimensions . . . . .	22
Figure 26.	SO-16L tube shipment (no suffix) . . . . .	24
Figure 27.	SO-16L tape and reel shipment (suffix "TR") . . . . .	24

# 1 Block diagram and pin description

Figure 1. Block diagram

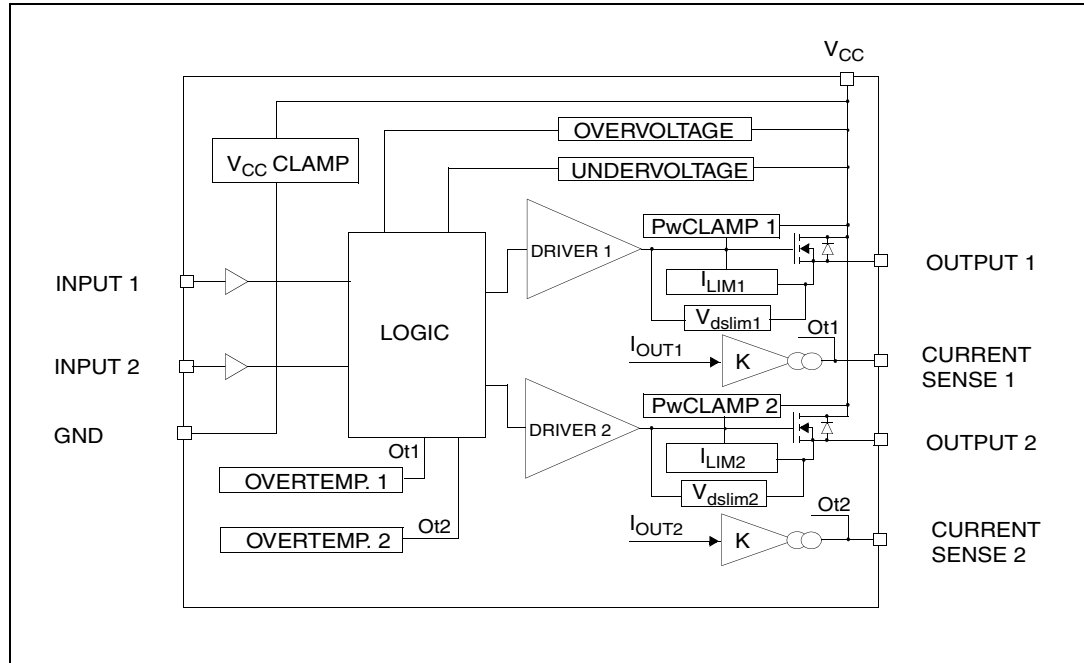

Figure 2. Configuration diagram (top view)

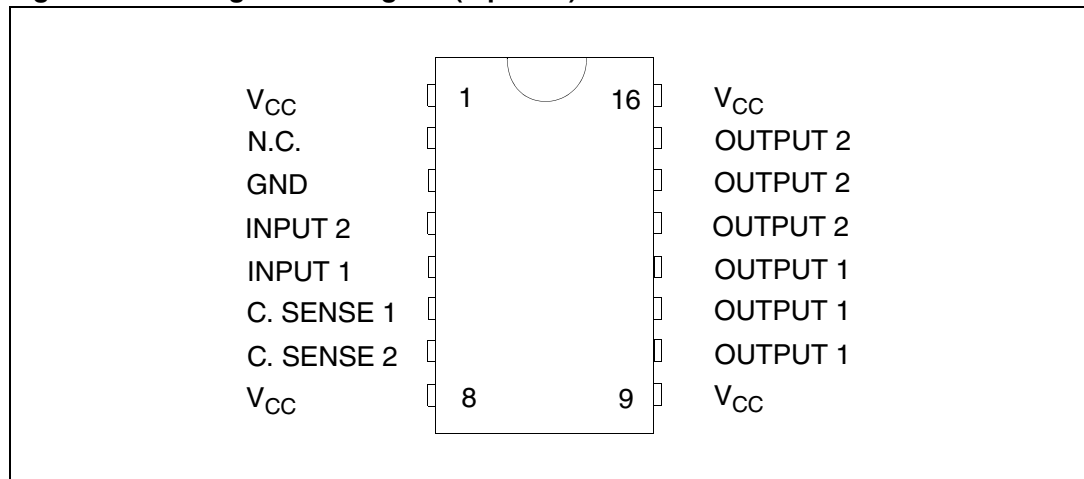
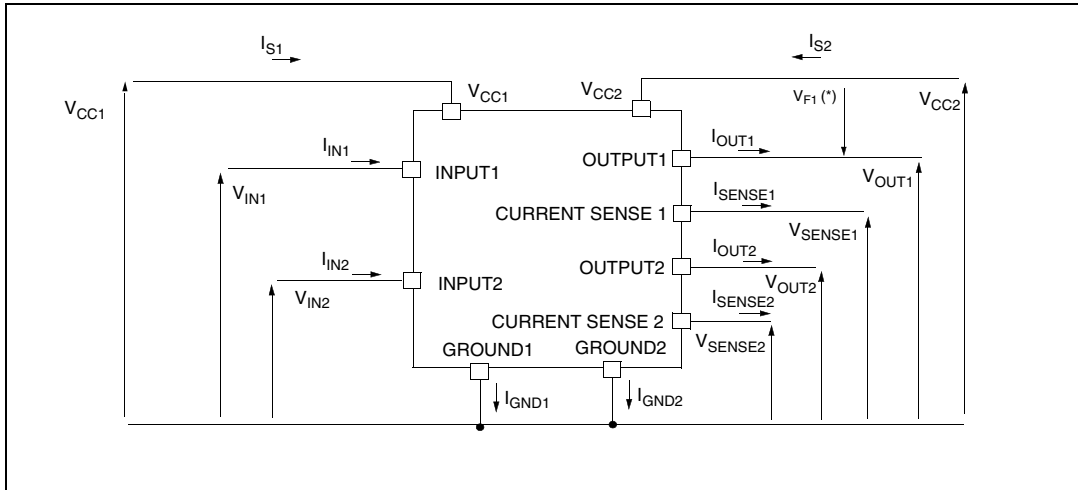

Table 2. Suggested connections for unused and not connected pins

Connection / pin	Current Sense	N.C.	Output	Input
Floating		X	X	X
To ground	Through 1KΩ resistor	X		Through 10KΩ resistor

## 2 Electrical specifications

Figure 3. Current and voltage conventions



Note:  $V_{Fn} = V_{CCn} - V_{OUTn}$  during reverse battery condition.

### 2.1 Absolute maximum ratings

Stressing the device above the rating listed in the “Absolute maximum ratings” table may cause permanent damage to the device. These are stress ratings only and operation of the device at these or any other conditions above those indicated in the operating sections of this specification is not implied. Exposure to Absolute maximum rating conditions for extended periods may affect device reliability. Refer also to the STMicroelectronics sure program and other relevant quality document.

Table 3. Absolute maximum ratings

Symbol	Parameter	Value	Unit
V <sub>CC</sub>	DC supply voltage	41	V
- V <sub>CC</sub>	Reverse DC supply voltage	- 0.3	V
- I <sub>gnd</sub>	DC reverse ground pin current	- 200	mA
I <sub>OUT</sub>	DC output current	Internally limited	A
- I <sub>OUT</sub>	Reverse DC output current	- 21	A
I <sub>IN</sub>	DC input current	+/- 10	mA
V <sub>CSENSE</sub>	Current Sense maximum voltage	- 3 + 15	V V
V <sub>ESD</sub>	Electrostatic discharge (human body model: R = 1.5KΩ; C = 100pF)		
	INPUT	4000	V
	CURRENT SENSE	2000	V
	OUTPUT	5000	V
	V <sub>CC</sub>	5000	V

**Table 3. Absolute maximum ratings (continued)**

Symbol	Parameter	Value	Unit
$E_{MAX}$	Maximum switching energy ( $L = 0.12\text{mH}$ ; $R_L = 0\Omega$ ; $V_{bat} = 13.5\text{V}$ ; $T_{jstart} = 150^\circ\text{C}$ ; $I_L = 40\text{A}$ )	136	mJ
$P_{tot}$	Power dissipation $T_C \leq 25^\circ\text{C}$	8.3	W
$T_j$	Junction operating temperature	Internally limited	$^\circ\text{C}$
$T_C$	Case operating temperature	- 40 to 150	$^\circ\text{C}$
$T_{stg}$	Storage temperature	- 55 to 150	$^\circ\text{C}$

## 2.2 Thermal data

**Table 4. Thermal data (per island)**

Symbol	Parameter	Value		Unit
$R_{thj-lead}$	Thermal resistance junction-lead	15		$^\circ\text{C}/\text{W}$
$R_{thj-amb}$	Thermal resistance junction-ambient	65 <sup>(1)</sup>	48 <sup>(2)</sup>	$^\circ\text{C}/\text{W}$

1. When mounted on a standard single-sided FR-4 board with  $0.5\text{cm}^2$  of Cu (at least  $35\ \mu\text{m}$  thick) connected to all  $V_{CC}$  pins. Horizontal mounting and no artificial air flow.
2. When mounted on a standard single-sided FR-4 board with  $6\text{cm}^2$  of Cu (at least  $35\ \mu\text{m}$  thick) connected to all  $V_{CC}$  pins. Horizontal mounting and no artificial air flow.

## 2.3 Electrical characteristics

Values specified in this section are for  $8V < V_{CC} < 36V$ ;  $-40^{\circ}C < T_j < 150^{\circ}C$ , unless otherwise stated.

**Table 5. Power**

Symbol	Parameter	Test conditions	Min.	Typ.	Max.	Unit
$V_{CC}$	Operating supply voltage		5.5	13	36	V
$V_{USD}$	Under-voltage shutdown		3	4	5.5	V
$V_{OV}$	Over-voltage shutdown		36			V
$R_{ON}$	On-state resistance	$I_{OUT} = 5A$ ; $T_j = 25^{\circ}C$ ; $I_{OUT} = 5A$ ; $T_j = 150^{\circ}C$ ; $I_{OUT} = 3A$ ; $V_{CC} = 6V$			35 70 120	m $\Omega$ m $\Omega$ m $\Omega$
$V_{CLAMP}$	Clamp voltage	$I_{CC} = 20mA$	41	48	55	V
$I_S$	Supply current	Off-state; $V_{CC} = 13V$ ; $V_{IN} = V_{OUT} = 0V$		12	40	$\mu A$
		Off-state; $V_{CC} = 13V$ ; $V_{IN} = V_{OUT} = 0V$ ; $T_j = 25^{\circ}C$		12	25	$\mu A$
		On-state; $V_{CC} = 13V$ ; $V_{IN} = 5V$ ; $I_{OUT} = 0A$ ; $R_{SENSE} = 3.9 k\Omega$			6	mA
$I_{L(off1)}$	Off-state output current	$V_{IN} = V_{OUT} = 0V$	0		50	$\mu A$
$I_{L(off2)}$	Off-state output current	$V_{IN} = 0V$ ; $V_{OUT} = 3.5V$	-75		0	$\mu A$
$I_{L(off3)}$	Off-state output current	$V_{IN} = V_{OUT} = 0V$ ; $V_{CC} = 13V$ ; $T_j = 125^{\circ}C$			5	$\mu A$
$I_{L(off4)}$	Off-state output current	$V_{IN} = V_{OUT} = 0V$ ; $V_{CC} = 13V$ ; $T_j = 25^{\circ}C$			3	$\mu A$

Note:  $V_{CLAMP}$  and  $V_{OV}$  are correlated. Typical difference is 5V.

**Table 6. Switching ( $V_{CC}=13V$ )**

Symbol	Parameter	Test conditions	Min.	Typ.	Max.	Unit
$t_{d(on)}$	Turn-on delay time	$R_L = 2.6\Omega$ (see <a href="#">Figure 4.</a> )		30		$\mu s$
$t_{d(off)}$	Turn-off delay time	$R_L = 2.6\Omega$ (see <a href="#">Figure 4.</a> )		30		$\mu s$
$dV_{OUT}/dt_{(on)}$	Turn-on voltage slope	$R_L = 2.6\Omega$ (see <a href="#">Figure 4.</a> )	See <a href="#">Figure 10.</a>			V/ $\mu s$
$dV_{OUT}/dt_{(off)}$	Turn-off voltage slope	$R_L = 2.6\Omega$ (see <a href="#">Figure 4.</a> )	See <a href="#">Figure 12.</a>			V/ $\mu s$

**Table 7.  $V_{CC}$  output diode**

Symbol	Parameter	Test conditions	Min.	Typ.	Max.	Unit
$V_F$	Forward on voltage	$-I_{OUT} = 2.3 A$ ; $T_j = 150^{\circ}C$			0.6	V



**Table 8. Logic inputs**

Symbol	Parameter	Test conditions	Min.	Typ.	Max.	Unit
$V_{IL}$	Input low-level voltage				1.25	V
$I_{IL}$	Low-level input current	$V_{IN} = 1.25V$	1			$\mu A$
$V_{IH}$	Input high-level voltage		3.25			V
$I_{IH}$	High-level input current	$V_{IN} = 3.25V$			10	$\mu A$
$V_{I(hyst)}$	Input hysteresis voltage		0.5			V
$V_{ICL}$	Input clamp voltage	$I_{IN} = 1mA$ $I_{IN} = -1mA$	6	6.8 -0.7	8	V V

**Table 9. Current sense ( $9V \leq V_{CC} \leq 16V$ )**

Symbol	Parameter	Test conditions	Min.	Typ.	Max.	Unit
$K_1$	$I_{OUT}/I_{SENSE}$	$I_{OUT} = 0.5A$ ; $V_{SENSE} = 0.5V$ ; $T_j = -40^\circ C \dots 150^\circ C$	3300	4400	6000	
$dK_1/K_1$	Current sense ratio drift	$I_{OUT} = 0.5A$ ; $V_{SENSE} = 0.5V$ ; $T_j = -40^\circ C \dots 150^\circ C$	-10		+10	%
$K_2$	$I_{OUT}/I_{SENSE}$	$I_{OUT} = 5A$ ; $V_{SENSE} = 4V$ ; $T_j = -40^\circ C$ $T_j = 25^\circ C \dots 150^\circ C$	4200 4400	4900 4900	6000 5750	
$dK_2/K_2$	Current sense ratio drift	$I_{OUT} = 5A$ ; $V_{SENSE} = 4V$ ; $T_j = -40^\circ C \dots 150^\circ C$	-6		+6	%
$K_3$	$I_{OUT}/I_{SENSE}$	$I_{OUT} = 15A$ ; $V_{SENSE} = 4V$ ; $T_j = -40^\circ C$ $T_j = 25^\circ C \dots 150^\circ C$	4200 4400	4900 4900	5500 5250	
$dK_3/K_3$	Current sense ratio drift	$I_{OUT} = 15A$ ; $V_{SENSE} = 4V$ ; $T_j = -40^\circ C \dots 150^\circ C$	-6		+6	%
$V_{SENSE}$	Max analog sense output voltage	$V_{CC} = 5.5V$ ; $I_{OUT} = 2.5A$ ; $R_{SENSE} = 10k\Omega$ $V_{CC} > 8V$ , $I_{OUT} = 5A$ ; $R_{SENSE} = 10k\Omega$	2 4			V V
$V_{SENSEH}$	Sense voltage in over-temperature condition	$V_{CC} = 13V$ ; $R_{SENSE} = 3.9k\Omega$		5.5		V
$R_{VSENSEH}$	Analog sense output impedance in over-temperature condition	$V_{CC} = 13V$ ; $T_j > T_{TSD}$ ; output open		400		$\Omega$
$t_{DSENSE}$	Current sense delay response	To 90% $I_{SENSE}^{(1)}$			500	$\mu s$

1. Current sense signal delay after positive input slope.

**Table 10. Protections<sup>(1)</sup>**

Symbol	Parameter	Test conditions	Min.	Typ.	Max.	Unit
$T_{TSD}$	Shutdown temperature		150	175	200	°C
$T_R$	Reset temperature		135			°C
$T_{hyst}$	Thermal hysteresis		7	15		°C
$I_{lim}$	Current limitation	$V_{CC} = 13V$ $5V < V_{CC} < 36V$	25	40	70 70	A A
$V_{demag}$	Turn-off output clamp voltage	$I_{OUT} = 2 A$ ; $V_{IN} = 0V$ ; $L = 6mH$	$V_{CC} - 41$	$V_{CC} - 48$	$V_{CC} - 55$	V
$V_{ON}$	Output voltage drop limitation	$I_{OUT} = 0.5 A$ ; $T_j = -40°C...150°C$		50		mV

1. To ensure long term reliability under heavy over-load or short circuit conditions, protection and related diagnostic signals must be used together with a proper software strategy. If the device operates under abnormal conditions this software must limit the duration and number of activation cycles.

**Table 11. Truth table**

Conditions	Input	Output	Sense
Normal operation	L	L	0
	H	H	Nominal
Over-temperature	L	L	0
	H	L	$V_{SENSEH}$
Under-voltage	L	L	0
	H	L	0
Over-voltage	L	L	0
	H	L	0
Short circuit to GND	L	L	0
	H	L	$(T_j < T_{TSD}) 0$
	H	L	$(T_j > T_{TSD}) V_{SENSEH}$
Short circuit to $V_{CC}$	L	H	0
	H	H	< Nominal
Negative output voltage clamp	L	L	0

**Table 12. Electrical transient requirements**

ISO T/R 7637/1 Test pulse	Test level				Delays and impedance
	I	II	III	IV	
1	- 25V <sup>(1)</sup>	- 50V <sup>(1)</sup>	- 75V <sup>(1)</sup>	- 100V <sup>(1)</sup>	2ms, 10Ω
2	+ 25V <sup>(1)</sup>	+ 50V <sup>(1)</sup>	+ 75V <sup>(1)</sup>	+ 100V <sup>(1)</sup>	0.2ms, 10Ω
3a	- 25V <sup>(1)</sup>	- 50V <sup>(1)</sup>	- 100V <sup>(1)</sup>	- 150V <sup>(1)</sup>	0.1μs, 50Ω
3b	+ 25V <sup>(1)</sup>	+ 50V <sup>(1)</sup>	+ 75V <sup>(1)</sup>	+ 100V <sup>(1)</sup>	0.1μs, 50Ω
4	- 4V <sup>(1)</sup>	- 5V <sup>(1)</sup>	- 6V <sup>(1)</sup>	- 7V <sup>(1)</sup>	100ms, 0.01Ω
5	+ 26.5V <sup>(1)</sup>	+ 46.5V <sup>(2)</sup>	+ 66.5V <sup>(2)</sup>	+ 86.5V <sup>(2)</sup>	400ms, 2Ω

1. All functions of the device are performed as designed after exposure to disturbance.
2. One or more functions of the device is not performed as designed after exposure and cannot be returned to proper operation without replacing the device.

**Figure 4. Switching characteristics**

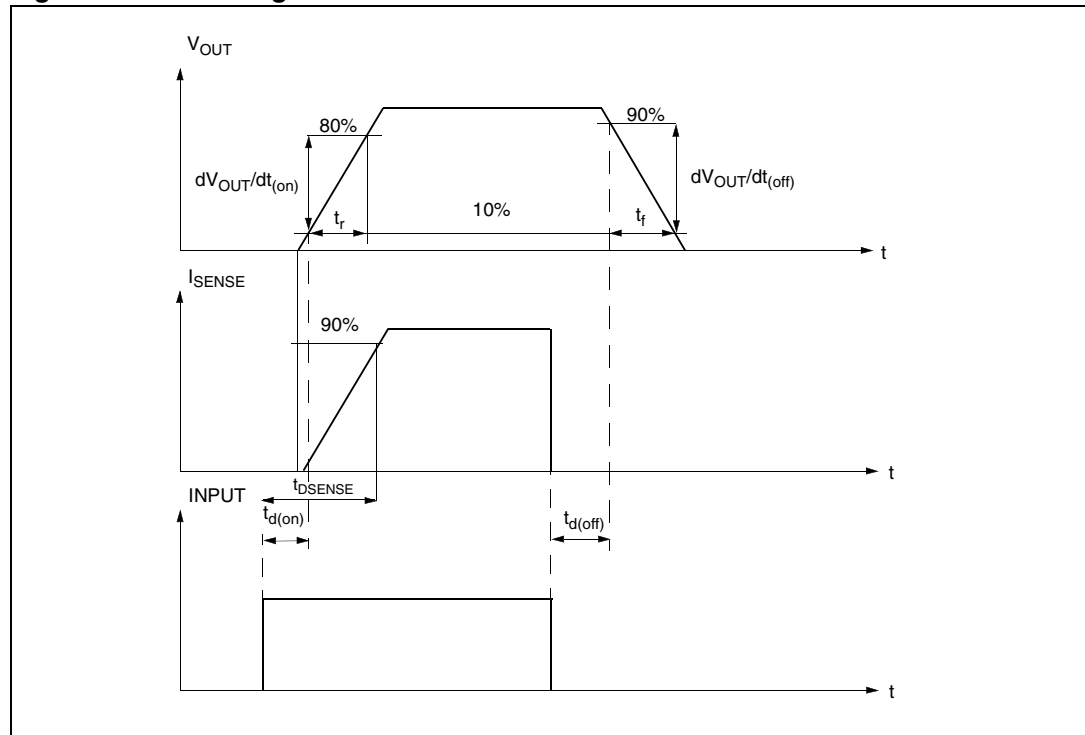

Figure 5.  $I_{OUT}/I_{SENSE}$  versus  $I_{OUT}$

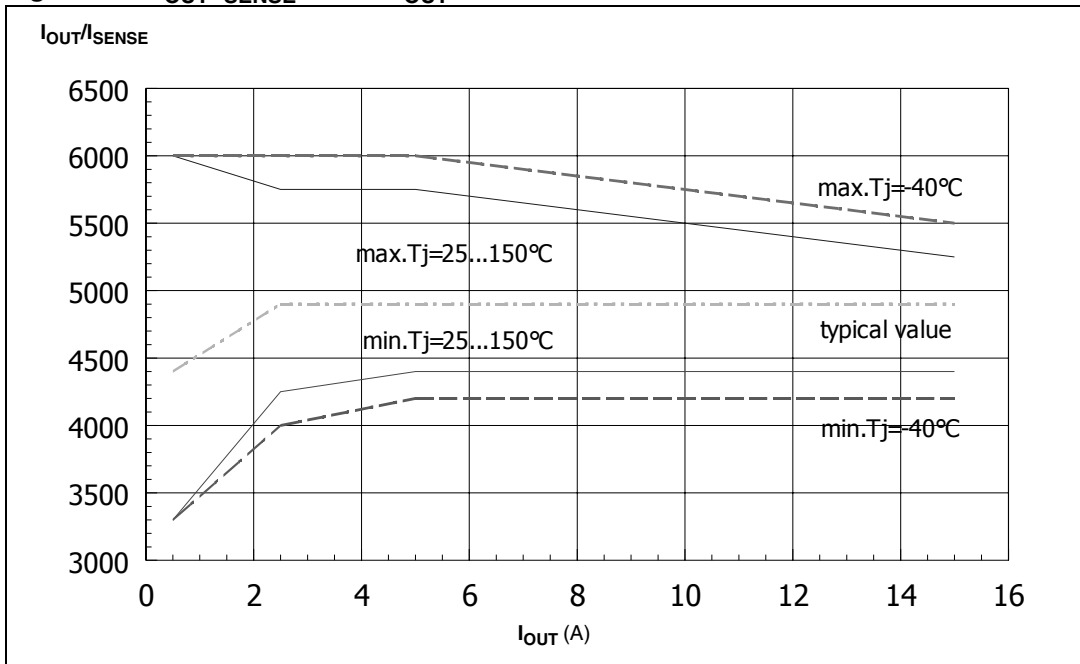
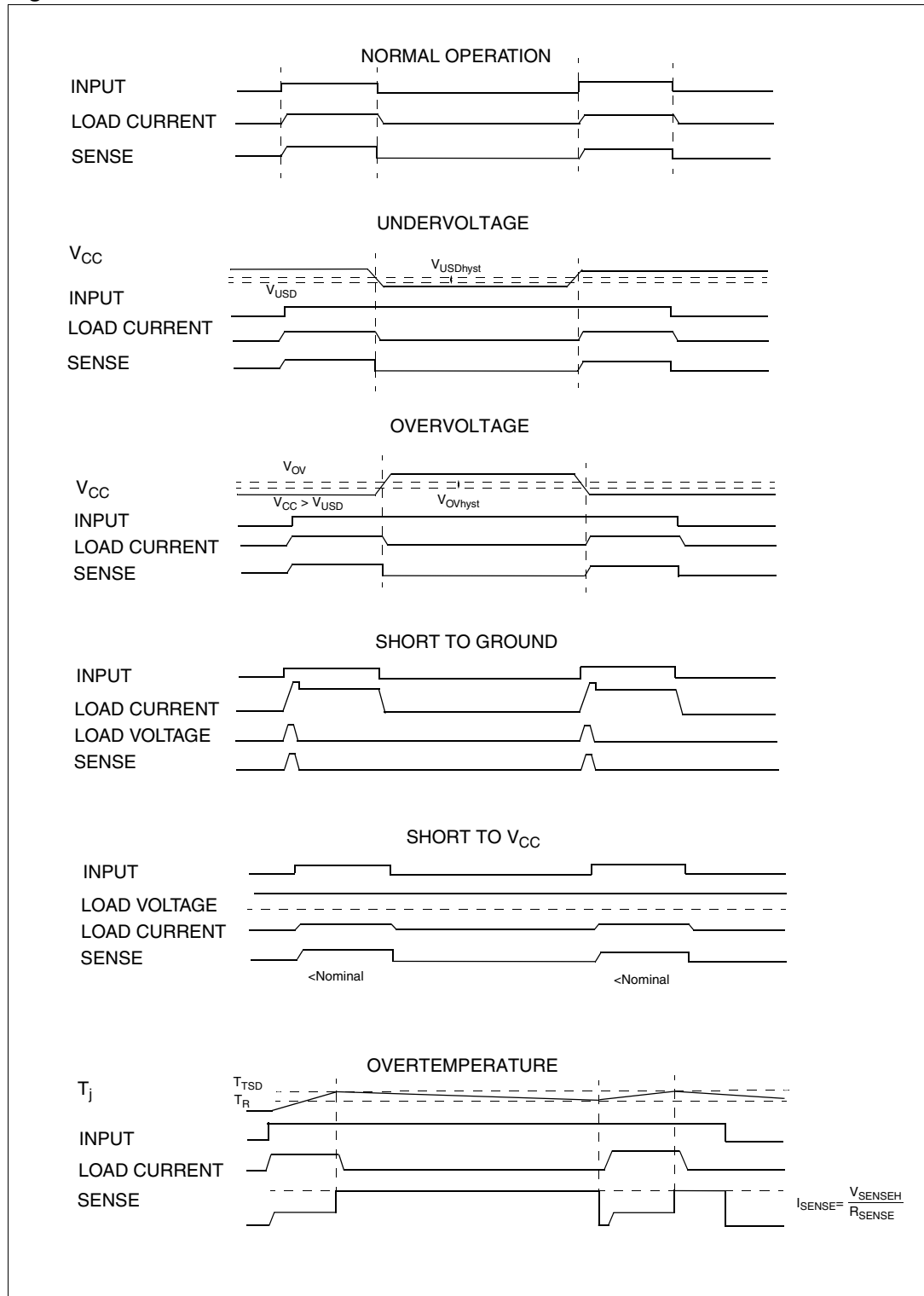
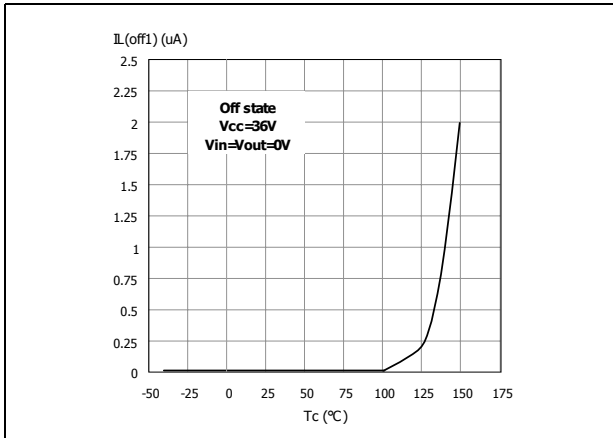

Figure 6. Waveforms



## 2.4 Electrical characteristics curves

**Figure 7. Off-state output current**



**Figure 8. High-level input current**

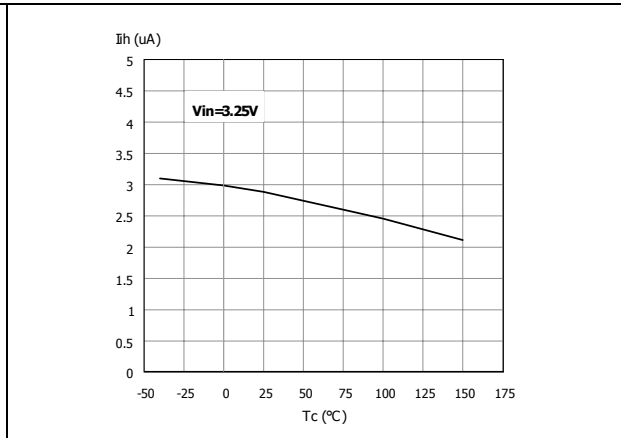

**Figure 9. Input clamp voltage**

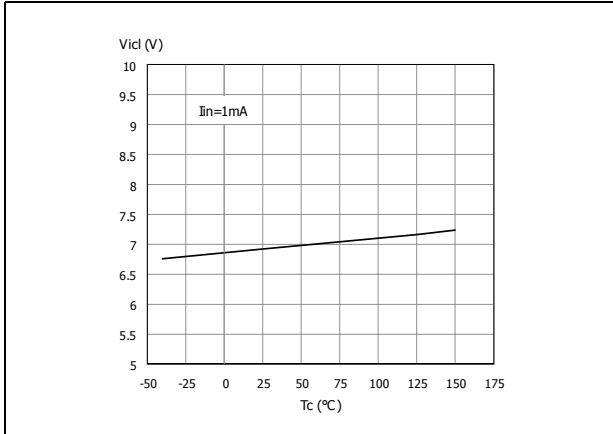

**Figure 10. Turn-on voltage slope**

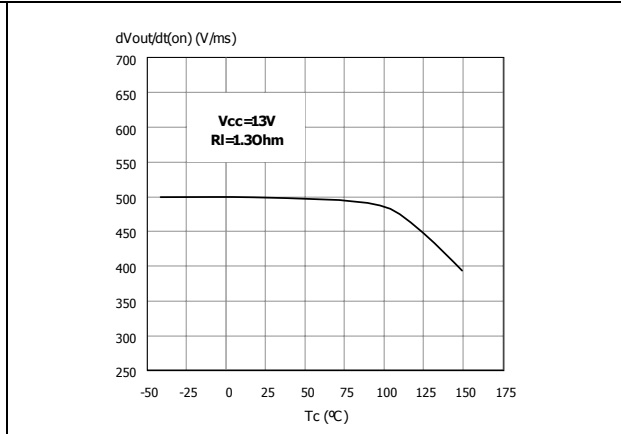

**Figure 11. Over-voltage shutdown**

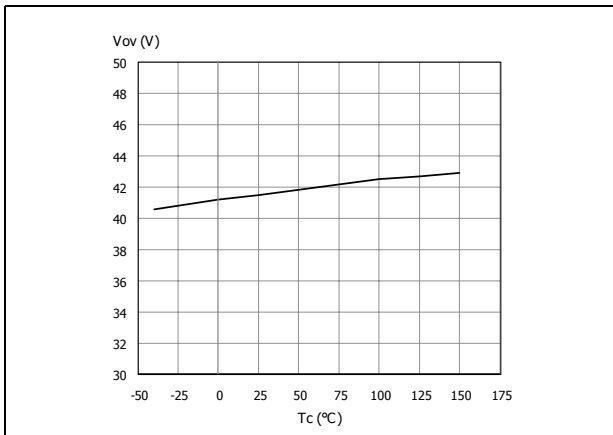

**Figure 12. Turn-off voltage slope**

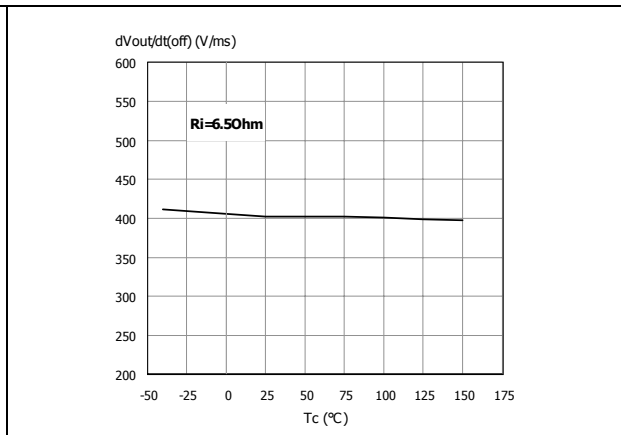

Figure 13.  $I_{LIM}$  vs  $T_{case}$

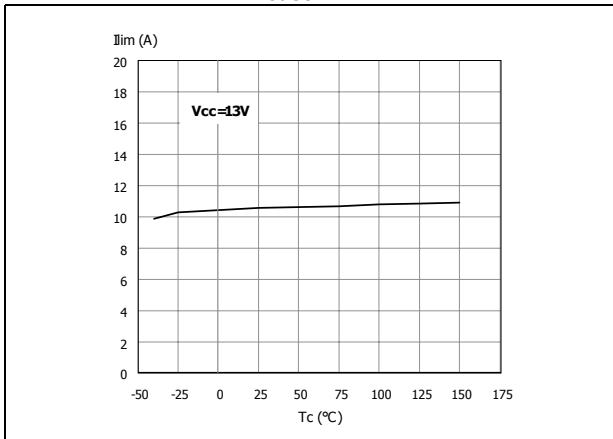

Figure 14. On-state resistance vs  $V_{CC}$

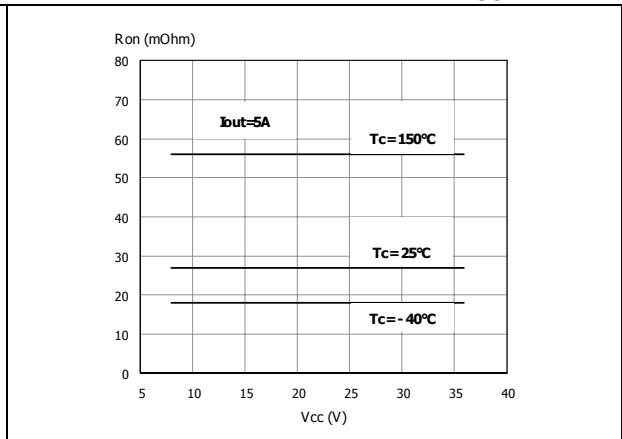

Figure 15. Input high-level

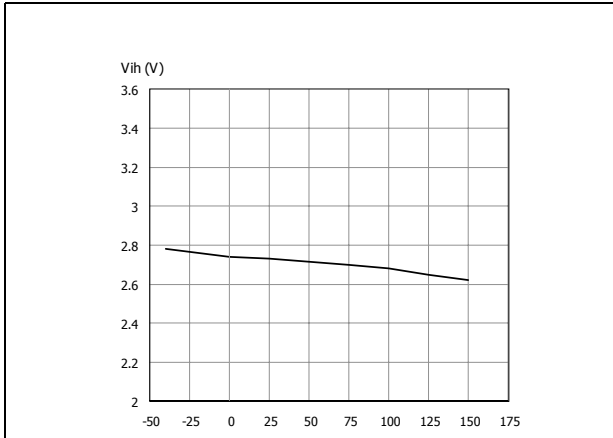

Figure 16. Input hysteresis voltage

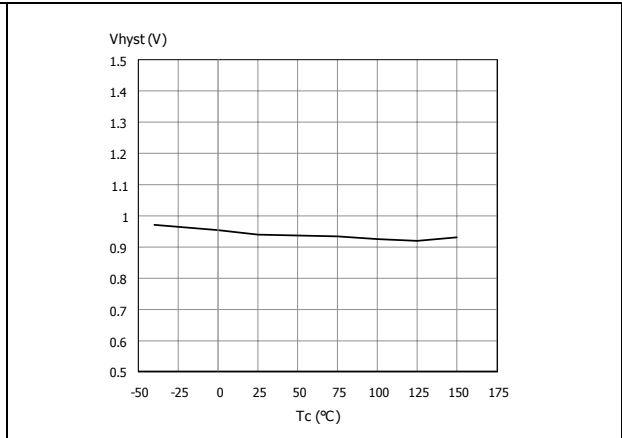

Figure 17. On-state resistance vs  $T_{case}$

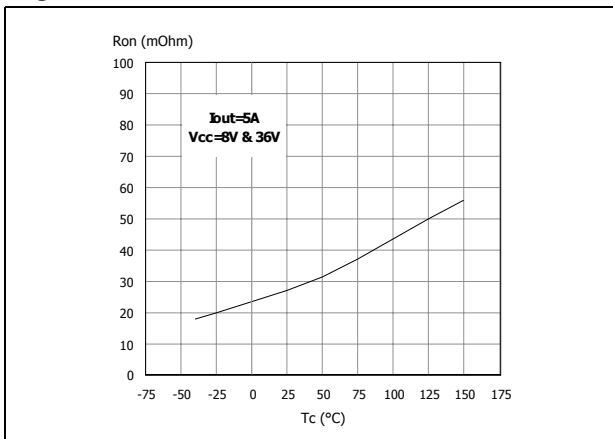
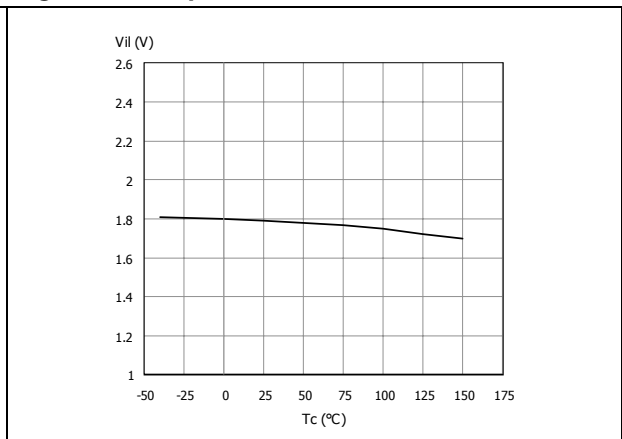
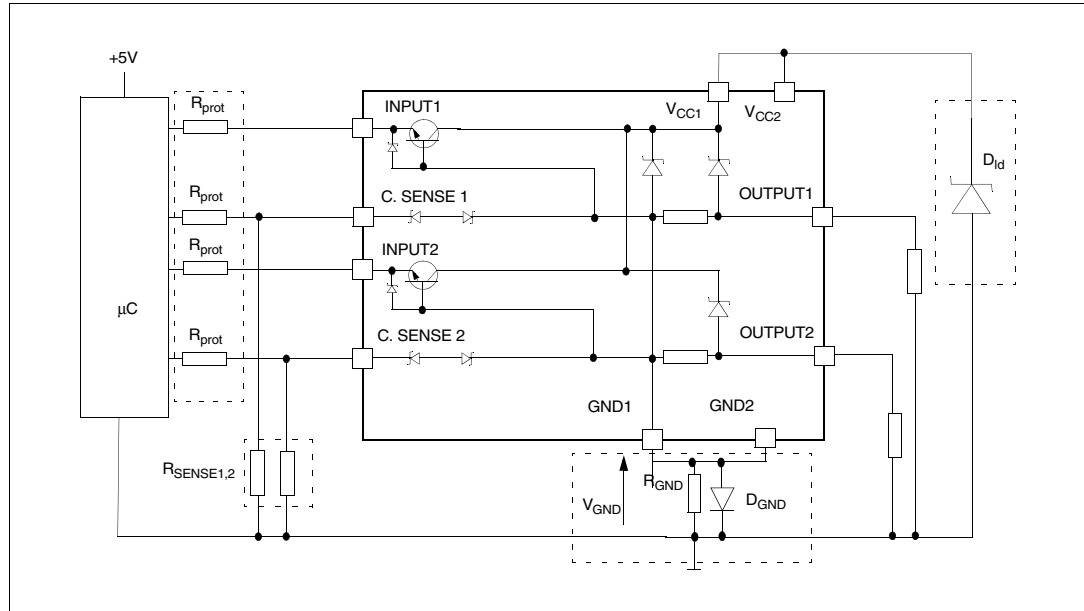

Figure 18. Input low-level



### 3 Application information

Figure 19. Application schematic



#### 3.1 GND protection network against reverse battery

##### 3.1.1 Solution 1: resistor in the ground line (R\_GND only)

This can be used with any type of load.

The following is an indication on how to dimension the R\_GND resistor.

1.  $R_{GND} \leq 600\text{mV} / (I_{S(on)max})$ .
2.  $R_{GND} \geq (-V_{CC}) / (-I_{GND})$

where  $-I_{GND}$  is the DC reverse ground pin current and can be found in the absolute maximum rating section of the device datasheet.

Power Dissipation in R\_GND (when  $V_{CC} < 0$ : during reverse battery situations) is:

$$P_D = (-V_{CC})^2 / R_{GND}$$

This resistor can be shared amongst several different HSDs. Please note that the value of this resistor should be calculated with formula (1) where  $I_{S(on)max}$  becomes the sum of the maximum on-state currents of the different devices.

Please note that if the microprocessor ground is not shared by the device ground then the R\_GND will produce a shift ( $I_{S(on)max} * R_{GND}$ ) in the input thresholds and the status output values. This shift will vary depending on how many devices are ON in the case of several high-side drivers sharing the same R\_GND.

If the calculated power dissipation leads to a large resistor or several devices have to share the same resistor then ST suggests to utilize Solution 2 (see below).



### 3.1.2 Solution 2: diode ( $D_{GND}$ ) in the ground line

A resistor ( $R_{GND} = 1k\Omega$ ) should be inserted in parallel to  $D_{GND}$  if the device drives an inductive load.

This small signal diode can be safely shared amongst several different HSDs. Also in this case, the presence of the ground network will produce a shift ( $\approx 600mV$ ) in the input threshold and in the status output values if the microprocessor ground is not common to the device ground. This shift will not vary if more than one HSD shares the same diode/resistor network.

Series resistor in INPUT and STATUS lines are also required to prevent that, during battery voltage transient, the current exceeds the absolute maximum rating.

Safest configuration for unused INPUT and STATUS pin is to leave them unconnected.

## 3.2 Load dump protection

$D_{ld}$  is necessary (Voltage Transient Suppressor) if the load dump peak voltage exceeds the  $V_{CC}$  max DC rating. The same applies if the device is subject to transients on the  $V_{CC}$  line that are greater than the ones shown in the ISO 7637-2: 2004(E) table.

## 3.3 MCU I/Os protection

If a ground protection network is used and negative transient are present on the  $V_{CC}$  line, the control pins will be pulled negative. ST suggests to insert a resistor ( $R_{prot}$ ) in line to prevent the  $\mu C$  I/Os pins to latch-up.

The value of these resistors is a compromise between the leakage current of  $\mu C$  and the current required by the HSD I/Os (Input levels compatibility) with the latch-up limit of  $\mu C$  I/Os.

$$-V_{CCpeak}/I_{latchup} \leq R_{prot} \leq (V_{OH\mu C} - V_{IH} - V_{GND}) / I_{IHmax}$$

Calculation example:

For  $V_{CCpeak} = -100V$  and  $I_{latchup} \geq 20mA$ ;  $V_{OH\mu C} \geq 4.5V$

$$5k\Omega \leq R_{prot} \leq 65k\Omega$$

Recommended values:  $R_{prot} = 10k\Omega$ .

### 3.4 Maximum demagnetization energy ( $V_{CC} = 13.5V$ )

Figure 20. Maximum turn-off current versus inductance

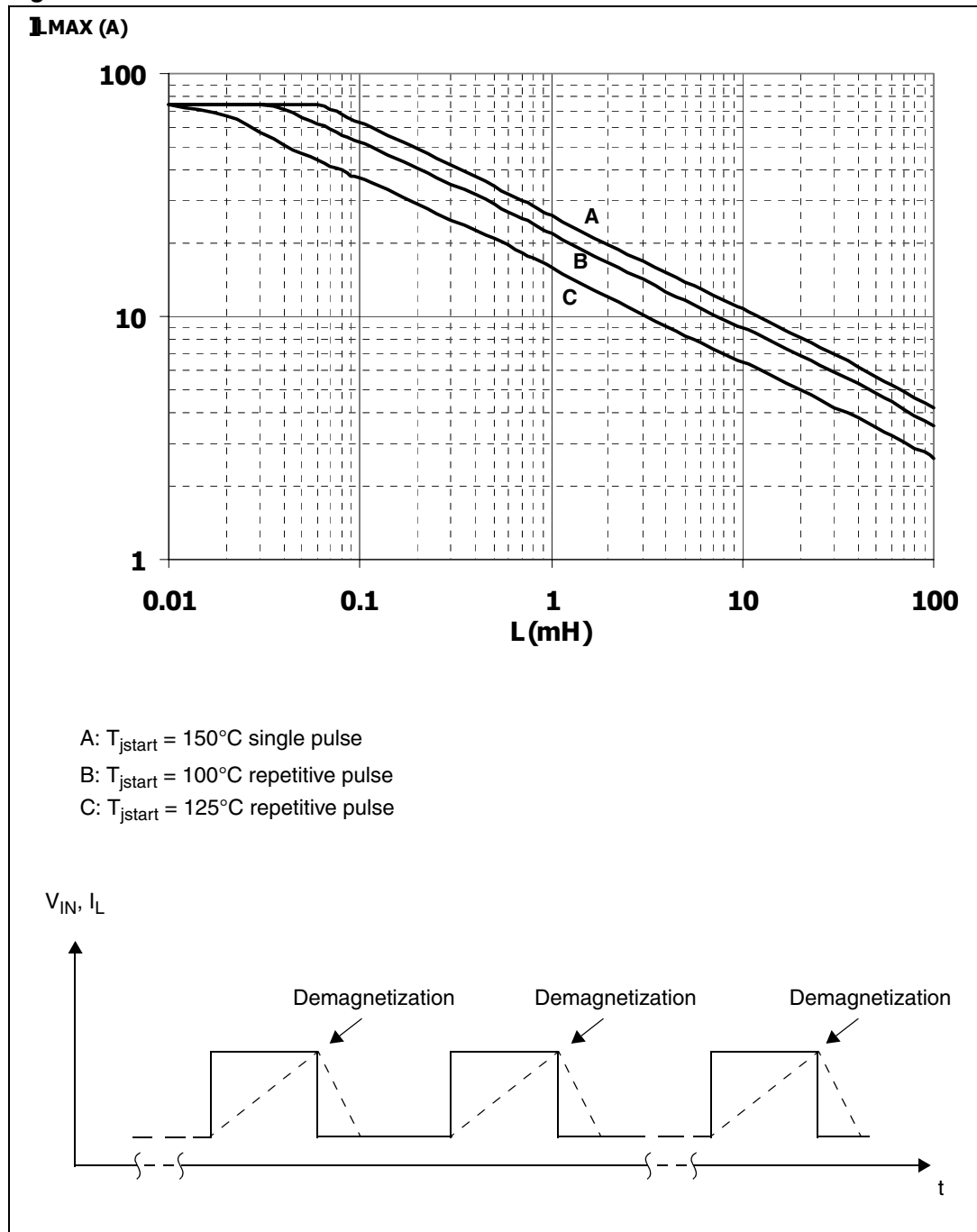

Note: Values are generated with  $R_L = 0 \Omega$ . In case of repetitive pulses,  $T_{jstart}$  (at beginning of each demagnetization) of every pulse must not exceed the temperature specified above for curves A and B.

## 4 Package and PCB thermal data

### 4.1 SO-16L thermal data

Figure 21. SO-16L PC board

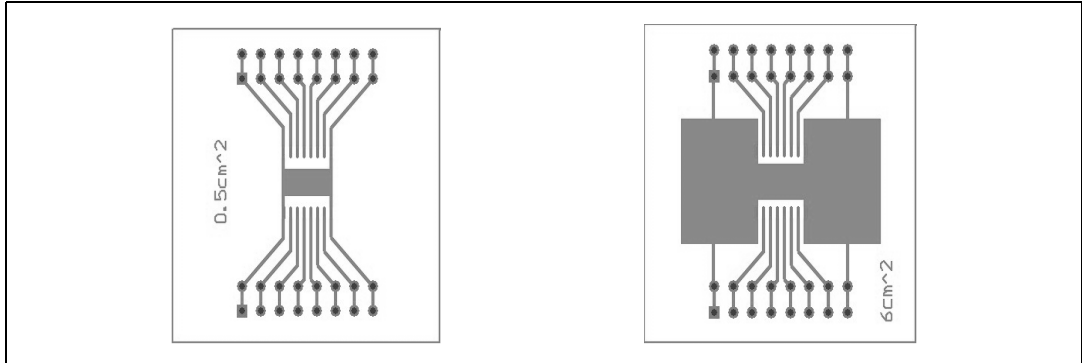

Note: Layout condition of  $R_{th}$  and  $Z_{th}$  measurements (PCB FR4 area = 41mm x 48mm, PCB thickness = 2mm, Cu thickness = 35 $\mu$ m, Copper areas: 0.5cm<sup>2</sup>, 6cm<sup>2</sup>).

Figure 22.  $R_{thj-amb}$  Vs PCB copper area in open box free air condition

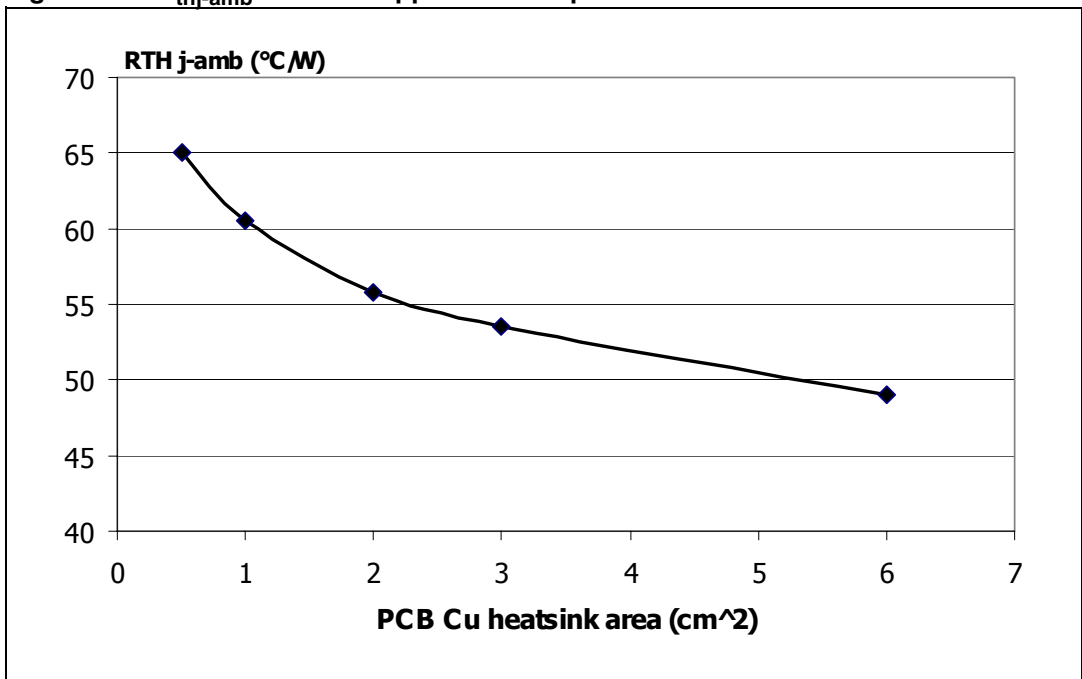
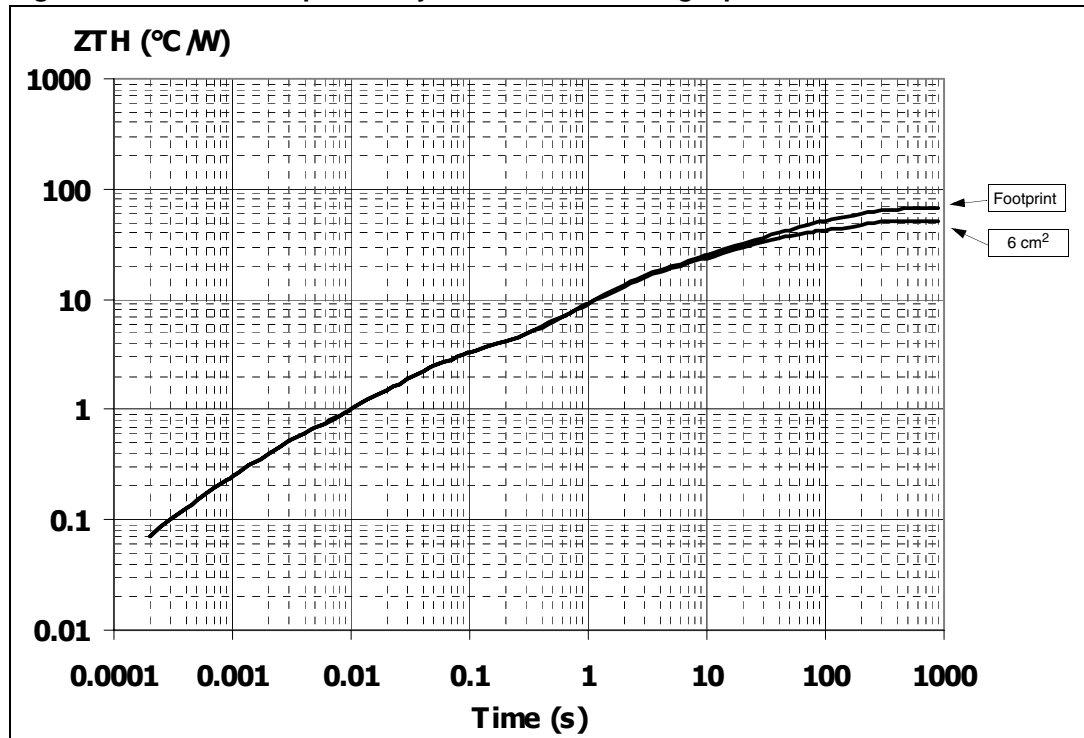

Figure 23. Thermal impedance junction ambient single pulse



Equation 1: pulse calculation formula

$$Z_{TH\delta} = R_{TH} \cdot \delta + Z_{THtp}(1 - \delta)$$

where  $\delta = t_p / T$

Figure 24. Thermal fitting model of a quad channel HSD in SO-16L

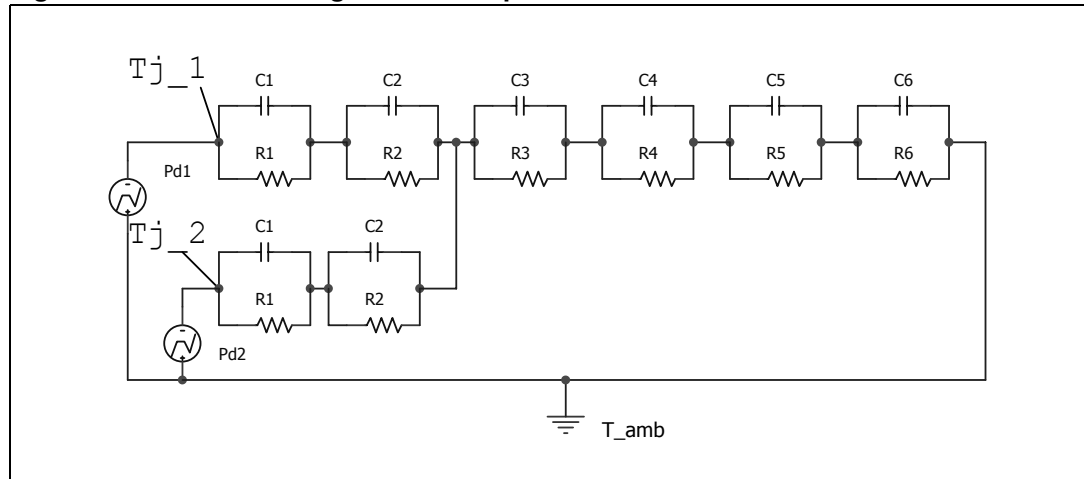

Table 13. Thermal parameters

Area / island (cm <sup>2</sup> )	Footprint	6
R1 (°C/W)	0.05	
R2 (°C/W)	0.3	
R3 (°C/W)	2.2	
R4 (°C/W)	12	
R5 (°C/W)	15	
R6 (°C/W)	37	22
C1 (W.s/°C)	0.001	
C2 (W.s/°C)	5E-03	
C3 (W.s/°C)	0.02	
C4 (W.s/°C)	0.3	
C5 (W.s/°C)	1	
C6 (W.s/°C)	3	5

## 5 Package and packing information

### 5.1 ECOPACK® packages

In order to meet environmental requirements, ST offers these devices in different grades of ECOPACK® packages, depending on their level of environmental compliance. ECOPACK® specifications, grade definitions and product status are available at: [www.st.com](http://www.st.com). ECOPACK® is an ST trademark.

Figure 25. SO-16L package dimensions

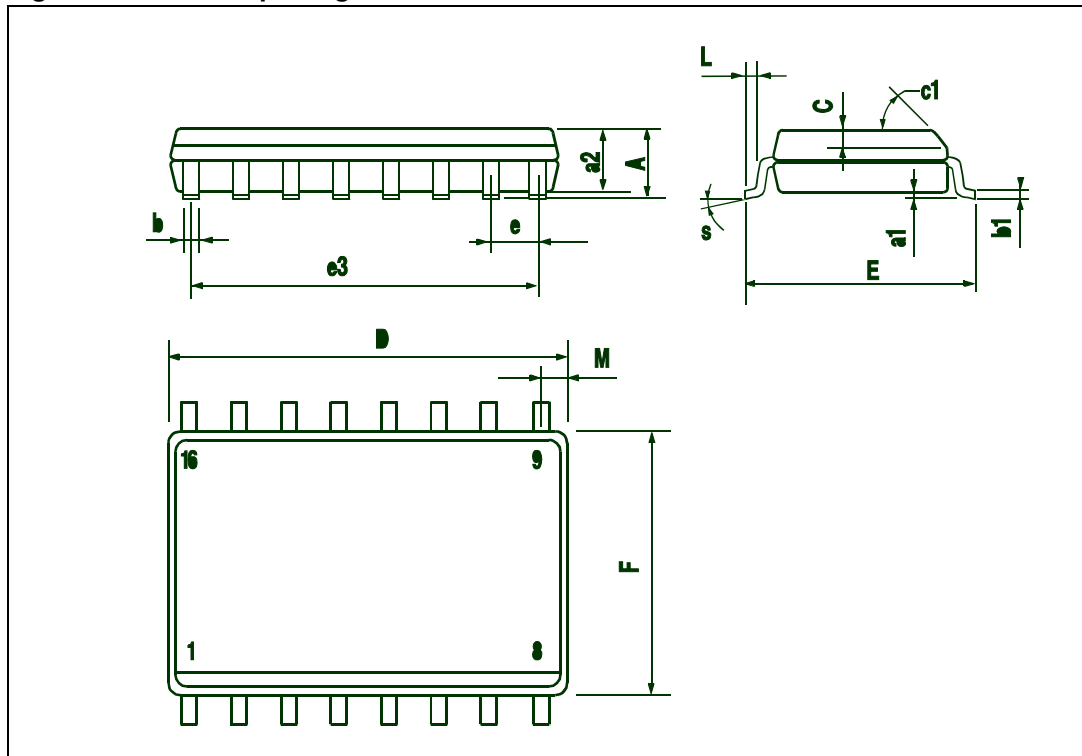

Table 14. SO-16L mechanical data

DIM.	mm.		
	Min.	Typ.	Max.
A			2.65
a1	0.1		0.2
a2			2.45
b	0.35		0.49
b1	0.23		0.32
C		0.5	
c1	45° (typ.)		
D	10.1		10.5
E	10.0		10.65
e		1.27	
e3		8.89	
F	7.4		7.6
L	0.5		1.27
M			0.75
S	8° (max.)		

## 5.2 SO-16L packing information

Figure 26. SO-16L tube shipment (no suffix)

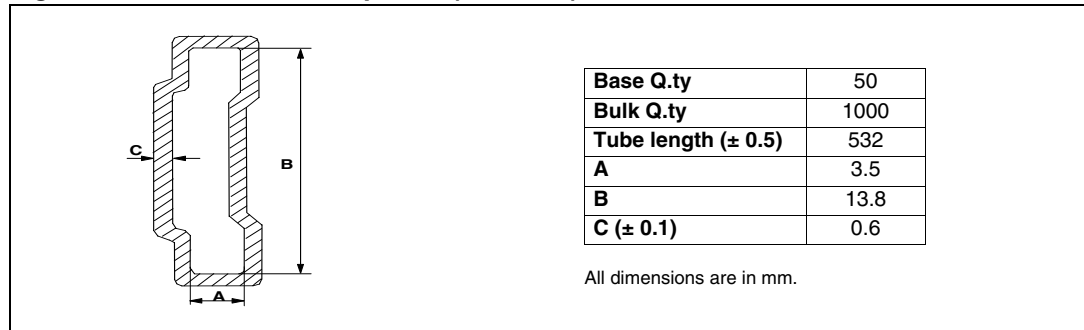
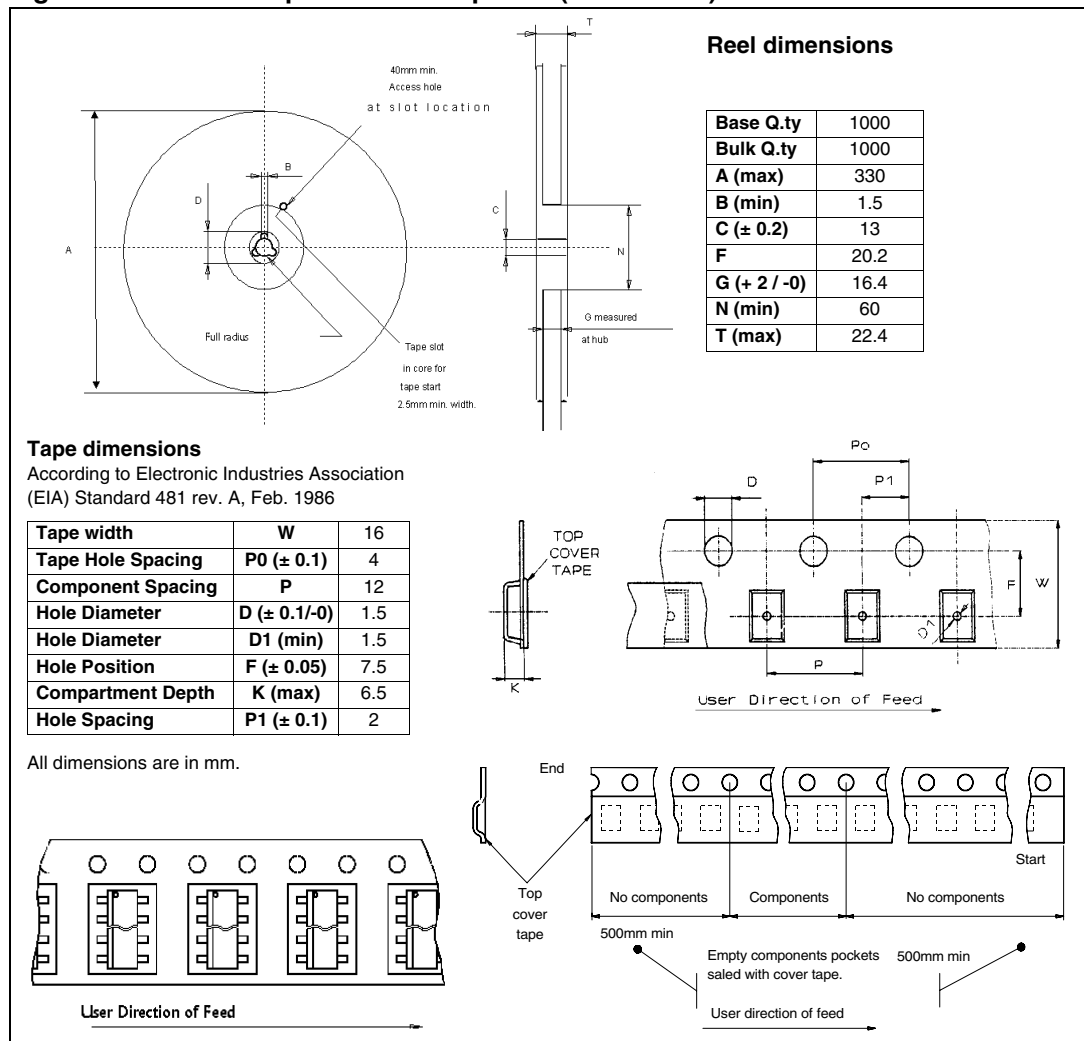

Figure 27. SO-16L tape and reel shipment (suffix “TR”)





## 6 Revision history

Table 15. Document revision history

Date	Revision	Changes
07-Jul-2004	1	Initial release.
09-Sep-2004	2	Minor changes. Current and voltage convention update (page 2). Configuration diagram (top view) and suggested connections for unused and n.c. pins insertion (page 2). 6 cm <sup>2</sup> Cu condition insertion in thermal data table (page 3). V <sub>CC</sub> - output diode section update (page 4). Revision history table insertion (page 34). Disclaimers update (page 35).
03-May-2006	3	Suggested connections for unused and n.c.pins correction.
17-Dec-2008	4	Document reformatted and restructured. Added content, list of figures and tables. Added <i>ECOPACK® packages</i> information.
25-Sep-2013	5	Updated disclaimer.

**Please Read Carefully:**

Information in this document is provided solely in connection with ST products. STMicroelectronics NV and its subsidiaries ("ST") reserve the right to make changes, corrections, modifications or improvements, to this document, and the products and services described herein at any time, without notice.

All ST products are sold pursuant to ST's terms and conditions of sale.

Purchasers are solely responsible for the choice, selection and use of the ST products and services described herein, and ST assumes no liability whatsoever relating to the choice, selection or use of the ST products and services described herein.

No license, express or implied, by estoppel or otherwise, to any intellectual property rights is granted under this document. If any part of this document refers to any third party products or services it shall not be deemed a license grant by ST for the use of such third party products or services, or any intellectual property contained therein or considered as a warranty covering the use in any manner whatsoever of such third party products or services or any intellectual property contained therein.

**UNLESS OTHERWISE SET FORTH IN ST'S TERMS AND CONDITIONS OF SALE ST DISCLAIMS ANY EXPRESS OR IMPLIED WARRANTY WITH RESPECT TO THE USE AND/OR SALE OF ST PRODUCTS INCLUDING WITHOUT LIMITATION IMPLIED WARRANTIES OF MERCHANTABILITY, FITNESS FOR A PARTICULAR PURPOSE (AND THEIR EQUIVALENTS UNDER THE LAWS OF ANY JURISDICTION), OR INFRINGEMENT OF ANY PATENT, COPYRIGHT OR OTHER INTELLECTUAL PROPERTY RIGHT.**

**ST PRODUCTS ARE NOT DESIGNED OR AUTHORIZED FOR USE IN: (A) SAFETY CRITICAL APPLICATIONS SUCH AS LIFE SUPPORTING, ACTIVE IMPLANTED DEVICES OR SYSTEMS WITH PRODUCT FUNCTIONAL SAFETY REQUIREMENTS; (B) AERONAUTIC APPLICATIONS; (C) AUTOMOTIVE APPLICATIONS OR ENVIRONMENTS, AND/OR (D) AEROSPACE APPLICATIONS OR ENVIRONMENTS. WHERE ST PRODUCTS ARE NOT DESIGNED FOR SUCH USE, THE PURCHASER SHALL USE PRODUCTS AT PURCHASER'S SOLE RISK, EVEN IF ST HAS BEEN INFORMED IN WRITING OF SUCH USAGE, UNLESS A PRODUCT IS EXPRESSLY DESIGNATED BY ST AS BEING INTENDED FOR "AUTOMOTIVE, AUTOMOTIVE SAFETY OR MEDICAL" INDUSTRY DOMAINS ACCORDING TO ST PRODUCT DESIGN SPECIFICATIONS. PRODUCTS FORMALLY ESCC, QML OR JAN QUALIFIED ARE DEEMED SUITABLE FOR USE IN AEROSPACE BY THE CORRESPONDING GOVERNMENTAL AGENCY.**

Resale of ST products with provisions different from the statements and/or technical features set forth in this document shall immediately void any warranty granted by ST for the ST product or service described herein and shall not create or extend in any manner whatsoever, any liability of ST.

ST and the ST logo are trademarks or registered trademarks of ST in various countries.

Information in this document supersedes and replaces all information previously supplied.

The ST logo is a registered trademark of STMicroelectronics. All other names are the property of their respective owners.

© 2013 STMicroelectronics - All rights reserved

STMicroelectronics group of companies

Australia - Belgium - Brazil - Canada - China - Czech Republic - Finland - France - Germany - Hong Kong - India - Israel - Italy - Japan - Malaysia - Malta - Morocco - Philippines - Singapore - Spain - Sweden - Switzerland - United Kingdom - United States of America

[www.st.com](http://www.st.com)

